



Redundant Power Supply Option



Can be mounted in Different styles



Dual card retainers

Specification

Construction

- Heavy-duty steel

Drive Bay

- External: 5.25 x1, 3.5" FDD x1
- Internal: 3.5" x1

Card Retainer

- Two locations for one card retainer

Air Filter

- One replaceable air filter

Cooling Fan

- One 12 cm ball-bearing fans

Indicator

- HDD x1+ Power on/off x1

Switch

Power on/off x1 , System reset x1

Speaker

- One 8dspeaker

Connector

- One 5-pin AT K/B connector

Standard Color

- Beige

Operating Temperature Range

- 0 to +40°C

Storage Temperature Range

- 0 to +70°C

Ordering Information

Relative Humidity

- 5% to 95%, non-condensing

Dimension

- 260(W) x 428(D) x 172(H) mm
- 10.24"(W) x 16.1"(D) x 6.77"(H)

Weight Net:

- Net: 8.5 kg (18.7 lb) ; Gross: 9.5 kg (20.9 lb)

Backplane:

- PBP-06I: 6-slot PISA bus PICMG backplane
- PBP-06P4: 6-slot (4xPCI) PICMG backplane
- PBP-06P3: 6-slot (3xPCI) PICMG backplane

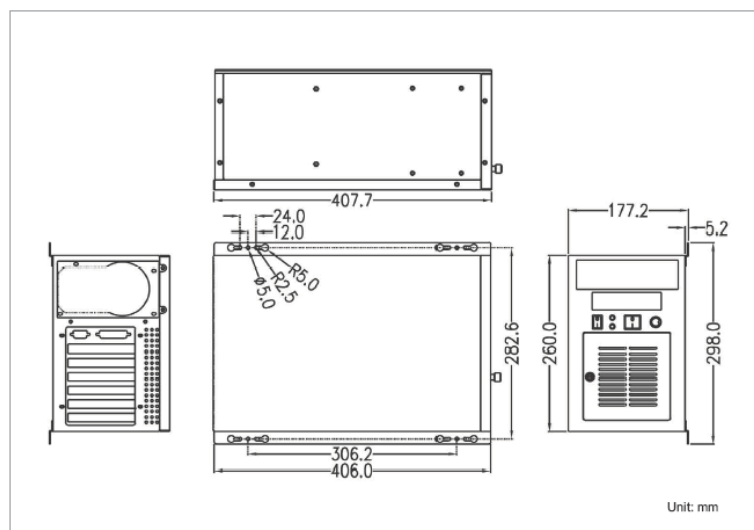

CAL-306-00

- 6-slot full-sized industrial node chassis